

Visit www.carrier.com

A Guide to Operating and Maintaining Your Single-Packaged Electric Heat Pump Units

NOTE: Read the entire instruction manual before starting the installation.

SAFETY CONSIDERATIONS

Note to Installer: This manual should be left with the equipment user.

⚠ WARNING

Do not store or use gasoline or other flammable vapors and liquids in the vicinity of these or any other appliances. Failure to follow this warning could result in fire, serious injury, or death.

⚠ WARNING

Do not use this unit if any part has been under water. Immediately call a qualified service technician to inspect the unit and to replace any part of the control system which has been under water. Failure to follow this warning could result in electrical shock, fire, serious injury, or death.

⚠ WARNING

Before performing recommended maintenance, be sure the main power switch to unit is turned off and lockout tag installed. Electric shock could cause serious injury or death.

STARTING OR SHUTTING UNITS OFF

1. To start either of these units:

- a. Turn on the electrical power supply to unit.
- b. Select temperature and set SYSTEM switch or MODE control to desired mode.

2. To shut this unit off:

NOTE: If the unit is being shut down because of a malfunction, call your dealer as soon as possible.

- a. Set system SWITCH or MODE control to OFF.
- b. Turn off the electrical power supply to unit and install lockout tag.

OPERATING YOUR HEAT PUMP

The operation of your heat pump system is controlled by the indoor thermostat. You simply adjust the thermostat and it maintains the indoor temperature at the level you select. Most thermostats of heat pump systems have 3 controls: a temperature control selector, a FAN control, and a SYSTEM or MODE control. Refer to your thermostat owner's manual for more information.

To better protect your investment and to eliminate unnecessary service calls, familiarize yourself with the following facts:

1. During heating, increasing the thermostat setting more than 2°F/1.1°C may cause the supplemental heaters to be turned on for a short period of time to satisfy the thermostat. Needless use of the supplementary heat reduces potential energy savings.

2. Ice or frost tends to form on the coil during winter heating operation. Your heat pump is designed to automatically melt the ice. **When in this defrost cycle, it is normal for steam or fog to rise from the outdoor unit.** Do not be alarmed!

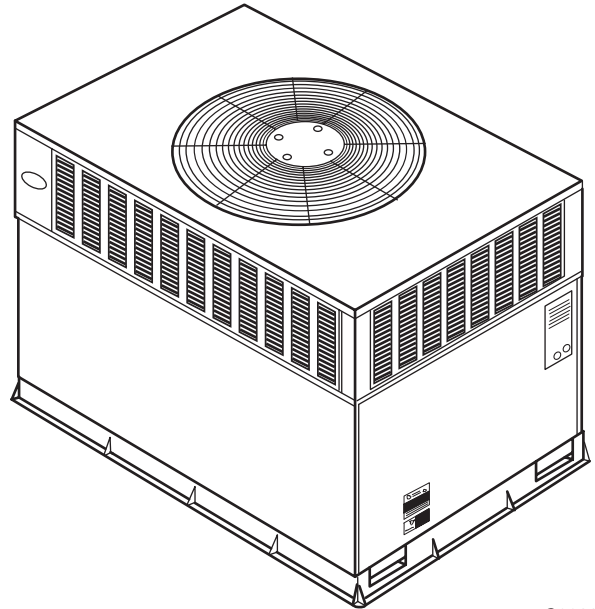

C990064

Fig. 1—Unit 50JZ (50Hz)

Step 1—Cooling Mode

With the SYSTEM or MODE control set to COOL, your heat pump will run in cooling mode until the indoor temperature is lowered to the level you have selected. On extremely hot days, your heat pump will run for longer periods at a time and have shorter "off" periods than on moderate days.

Step 2—Heating Mode

With the SYSTEM or MODE control of your indoor thermostat set to HEAT, your heat pump will run in heating mode until room temperature is raised to the level you have selected. Of course, your heat pump will run for longer periods to maintain a comfortable environment on cooler days and nights than on moderate ones.

Step 3—Supplemental Heat

Your heat pump is your primary heating source. Your system may also be equipped with a supplemental heating source such as electric heat. On cold days and nights, your system will automatically turn on the supplemental heat in order to maintain the level of comfort you have selected.

When your heat pump needs additional heat to keep you comfortable, your Carrier electronic thermostat will turn on the supplemental heat (if equipped) and display the "AUX HT" message.

Table 1—Indoor-Air Filter Data

UNIT SIZE 50JZ (50HZ)	024	030	036	048	060
RETURN-AIR FILTERS (mm.) Throwaway	20" x 20" (508 x 508)	20" x 20" (508 x 508)	20" x 24" (508 x 609.6)	24" x 30" (609.6 x 762)	24" x 30" (609.6 x 762)

Step 4—Defrost Mode

When your heat pump is providing heat to your home or office and the outdoor temperature drops below 45°F/7.2°C, moisture may begin to freeze on the surface of the coil. If allowed to build up, this ice would impede airflow across the coil and reduce the amount of heat absorbed from the outside air. So, to maintain energy-efficient operation, your heat pump has an automatic defrost mode.

The defrost mode starts at a preset time interval of 30 minutes, although, it may be reset to 60, 90 or 120 minutes. Defrost will start at the preset time only if the ice is sufficient to interfere with normal heating operation.

After the ice is melted from the coil, or after a maximum of 10 minutes in defrost mode, these units automatically switch back to normal heating operation.

Do not be alarmed if steam or fog appears at the outdoor unit during defrost mode. Water vapor from the melting ice may condense into a mist in the cold outside air.

During certain weather conditions such as heavy snow and freezing rain it is not uncommon for ice to build up on the unit grille. This is normal for these weather conditions. Do not attempt to remove the ice from the unit grille. This condition will not affect the proper function of the unit and will clear within a few days.

Step 5—Emergency Heat Mode

This allows your supplemental heating source to keep your home or office warm until your heat pump can be serviced.

MAINTENANCE AND SERVICE

This section discusses maintenance that should be performed by your dealer and care you, as the owner, may wish to handle for your new heat pump.

ROUTINE MAINTENANCE

All routine maintenance should be handled by skilled, experienced personnel. Your dealer can help you establish a standard procedure.

For your safety, keep your unit area clear and free of combustible materials, gasoline, and other flammable liquids and vapors.

To assure proper functioning of your unit, flow of condenser air must not be obstructed from reaching the unit. Minimum clearance from the top of the unit is 48 in./1219 mm. Clearance of at least 36 in./914 mm is required on sides except the power entry side (42 in./1067 mm clearance) and the duct side (12 in./305 mm minimum clearance).

MAINTENANCE AND CARE FOR THE EQUIPMENT OWNER

Before proceeding with those things you might want to maintain yourself, please carefully consider the following:

⚠ WARNING

1. TURN OFF ELECTRICAL POWER TO YOUR UNIT BEFORE SERVICING OR PERFORMING MAINTENANCE. ELECTRIC SHOCK COULD CAUSE SERIOUS INJURY OR DEATH.
2. When removing access panels or performing maintenance functions inside your unit, be aware of sharp sheet metal parts and screws. Although special care is taken to keep sharp edges to a minimum, be extremely careful when handling parts or reaching into the unit.

Air Filters

The air filter(s) should be checked at least every 3 or 4 weeks and changed or cleaned whenever it becomes dirty. Dirty filters produce excessive stress on the blower motor and can cause the motor to overheat and shut down. Table 1 indicates the correct filter size for your unit. Refer to Fig. 2 to access the filters.

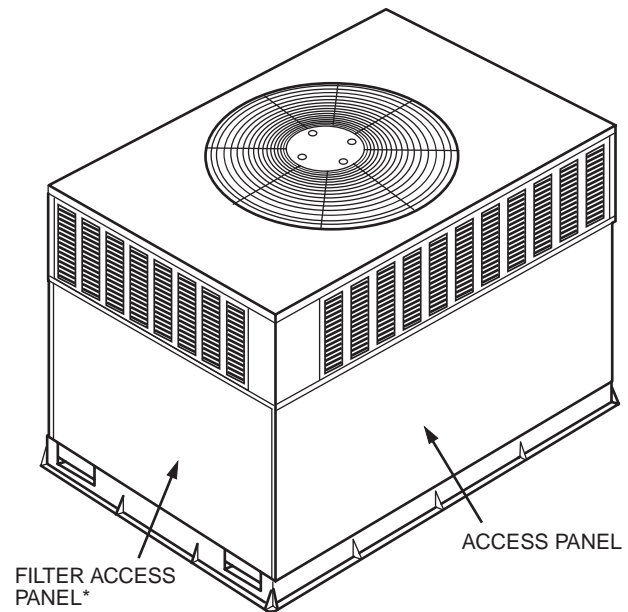

*For accessory filter rack.

C99094

Fig. 2—Filter Access Panel—Vertical Supply Shown

To replace or inspect filters (or accessory filter rack when supplied):

1. Remove the filter access panel using a 5/16-in. (7.9 mm) nut driver or wrench.
2. Remove the filter(s) by pulling it out of the unit. If the filter(s) is dirty, clean or replace with a new one.

When installing the new filter(s), note the direction of the airflow arrows on the filter frame.

If you have difficulty locating your air filter(s) or have questions concerning proper filter maintenance, contact your dealer for instructions. When replacing filters, always use the same size and type of filter that was supplied, originally, by the installer.

⚠ CAUTION

Never operate your unit without the filter(s) in place. Failure to heed this warning may result in damage to the blower motor and/or compressor. An accumulation of dust and lint on internal parts of your unit can cause loss of efficiency and, in some cases, a fire.

Fans and Fan Motor

Periodically, check the condition of fan wheels and housings and fan-motor shaft bearings. Contact your dealer for the required annual maintenance.

Indoor and Outdoor Coils

Cleaning of the coils should only be done by qualified service personnel. Contact your dealer for the required annual maintenance.

Condensate Drain

The drain pan and condensate drain line should be checked and cleaned at the same time the cooling coils are checked by your dealer.

Compressor

All compressors are factory-shipped with a normal charge of the correct type refrigeration grade oil. A compressor should rarely require additional oil.

Condenser Fan

⚠ CAUTION

Do not poke sticks, screwdrivers, or any other objects into revolving fan blades. Injury or equipment damage may result.

The fan must be kept free of all obstructions to ensure proper cooling. Contact your dealer for any required service.

Electrical Controls and Wiring

Electrical controls are difficult to check without proper instruments. If there are any discrepancies in the operating cycle, contact your dealer and request service.

Refrigerant Circuit

The refrigerant circuit is difficult to check for leaks without the proper equipment. If inadequate cooling is suspected, contact your local dealer for service.

⚠ WARNING

System under pressure. Relieve pressure and recover all refrigerant before system repair or final unit disposal to avoid serious injury or death. Use all service ports and open all flow-control devices, including solenoid valves.

Unit Panels

After performing any maintenance or service on either of these units, be sure all panels are fastened securely in place to prevent rain from entering unit cabinet and to prevent disruption of the correct unit airflow pattern.

REGULAR DEALER MAINTENANCE

In addition to the type of routine maintenance you might be willing to perform, your unit should be inspected regularly by a properly trained service technician. An inspection (preferably each year, but at least every other year) should include the following:

1. Inspection and, if required, cleaning of the outdoor and indoor coils.
2. Inspection and, if required, cleaning of the indoor coil drain pan.
3. Inspection and cleaning of blower wheel housing and motor.
4. Inspection of all supply-air and return-air ducts for leaks, obstructions, and insulation integrity. Any problems found should be resolved at this time.
5. Inspection of the unit base to ensure that no cracks, gaps, etc., exist which may cause a hazardous condition.
6. Inspection of the unit casing for signs of deterioration.
7. Inspection of all electrical wiring and components to assure proper connection.
8. Inspection for leaks in the refrigerant circuit. Pressure-check to determine appropriate refrigerant charge.
9. Inspection of compressor oil level by service person to ensure proper oil level is maintained in the compressor when it is installed and running.
10. Operational check of the unit to determine working conditions. Repair or adjustment should be made at this time.

Your servicing dealer may offer an economical service contract that covers seasonal inspections. Ask for further details.

Complete service instructions can be found in each unit's Installation, Start-Up and Service Instructions.

BEFORE YOU CALL FOR SERVICE ...

...check for several easily-solved problems.

If insufficient heating or cooling is suspected:

() Check for sufficient airflow. Check the air filter for dirt. Check for blocked return-air or supply-air grilles. Be sure they are open and unobstructed. If these checks do not reveal the cause, call your servicing dealer.

If your unit is not operating at all, check the following list for easy solutions:

() Check to be sure that your thermostat temperature selector is set below the indoor temperature during the cooling season or above the indoor temperature during heating season. Be sure the SYSTEM switch or MODE control is in the COOL or HEAT position and not in the OFF position.

() If your unit still fails to operate, call your servicing dealer for troubleshooting and repairs. Specify the model and serial numbers of your unit. (Record them in this manual in the space provided.) If the dealer knows exactly which unit you have, he may be able to offer suggestions over the phone, or save valuable time through knowledgeable preparation for the service call.

IN CASE OF TROUBLE

If you perform the steps above and unit performance is still unsatisfactory, shut off the unit and call your dealer.

Dealer's Name _____

Telephone _____

Unit Model _____

Unit Serial Number _____

Manufacturer reserves the right to discontinue, or change at any time, specifications or designs without notice and without incurring obligations.